

# 4X4 TRUCK CAMPER

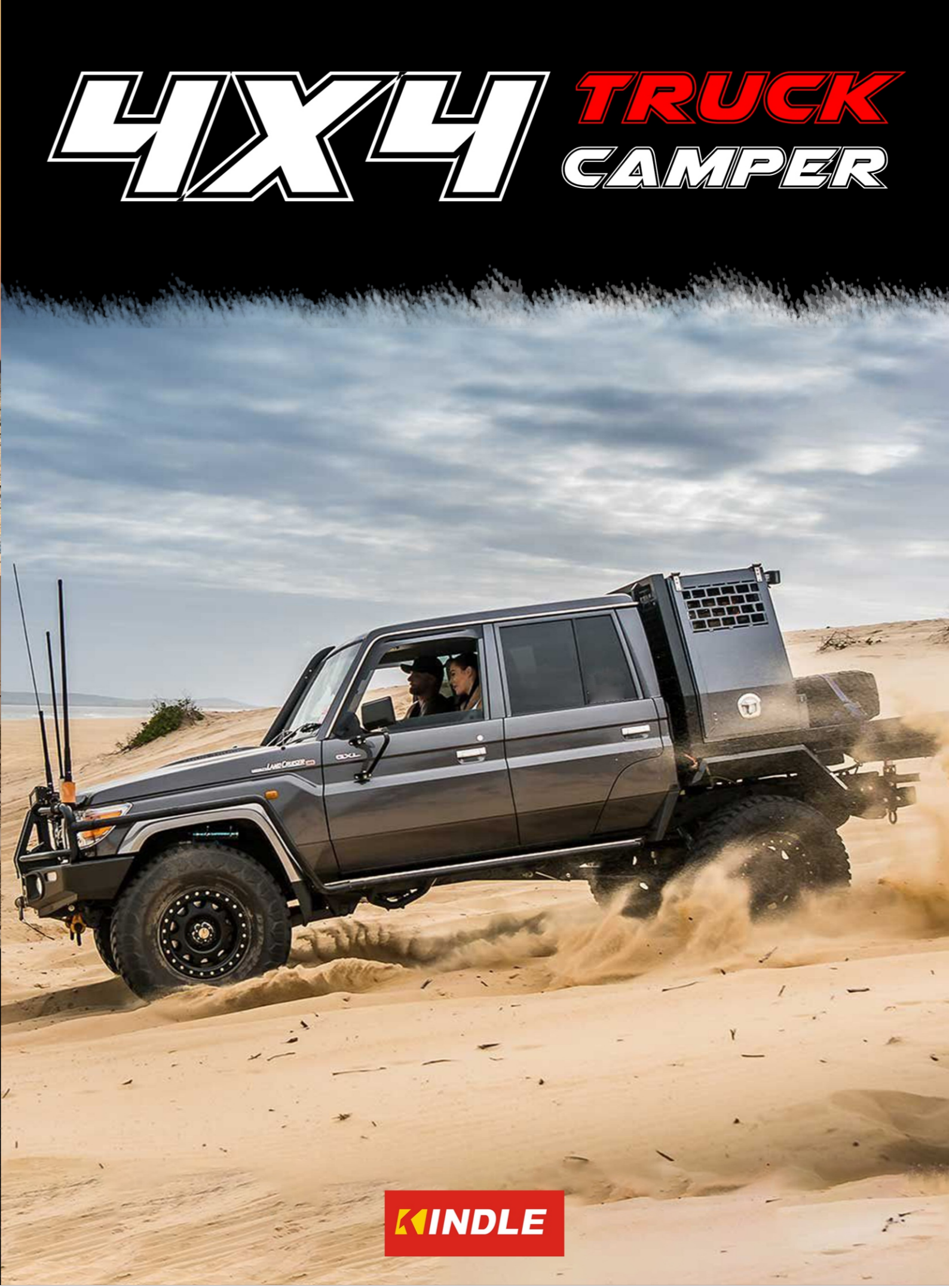

**KINDLE**

**Foshan Kindle Technology Co., Ltd**

Tel : +86-757-81632928  
+86-757-81632929  
+86-757-81632939

Website : [www.ecocampor.com](http://www.ecocampor.com)  
Address : No. 7, Huiying Road, Baini town, Sanshui District,  
Foshan City, Guangdong Province, China.

**KINDLE**





## CONTENT

- ▼ TRAY AND CANOPY PACKAGE . . . . . 1
- ▼ ADVANCED MODEL ALUMINUM UTE CANOPY WITH ROOF TOP TENT . . . . . 2
- ▼ FORD RANGER DOUBLE CAB ALUMINIUM CANOPY CAMPER . . . . . 3
- ▼ MULTI-FUNCTIONAL ALUMINIUM DUAL CAB CANOPY . . . . . 4
- ▼ LIGHT WEIGHT MID SIZE SLIDE IN TRUCK CAMPER . . . . . 5
- ▼ FLATBED POP UP TRUCK CAMPER . . . . . 7
- ▼ FIBERGLASS MOLDULAR SLIDE ON TRUCK CAMPER . . . . . 9
- ▼ EXPEDITION TRUCK CAMPER . . . . . 11

## ABOUT US COMPANY

With over 37 years experience in the sheet metal fabrication and customized ute accessories industry, Foshan Kindle Plate Working Co., Ltd. has been changed the name into FOSHAN KINDLE TECHNOLOGY CO., LTD. since 2020, which is one of the branch of KINLIFE GROUP. KINDLE TECHNOLOGY CO., LTD. is a professional manufacturer of 4WD UTE products ranges from Metal Truck Toolboxes, all UTE Alloy Canopies, UTE Tray, Dog Cages, Fridge Slide to all kinds of custom products for 4wd pickup vehicle of Aluminum Ute canopies. In additional, precision sheet metal fabrication products, such as flower pot, telephone booth and racing pit toolbox. Last but not the least, camping products and water sport products are also one of our main business lines, such as RV caravan & camper trailers, utility trailers and marine pontoon



boats. At present, FOSHAN KINDLE TECHNOLOGY CO., LTD. locates in Sansui district, Foshan city, Guangdong Province, China. Having a 43,000 square meters of manufacturing facility, the workshop divided into 3 production divisions, steel products, stainless steel and aluminum products are all individually being manufactured. Regarding the advanced equipment, we not only have 3 laser cutting machine from Germany and Japan, and some standard CNC punching & bending machines, but also the workshop even equipping with an extraordinary huge in-house automatic painting line, and 10 sets of big pre-treatment pools to insure the powder coating quality. With the outstanding big elevator (size is 3.9mx6m), which is easy for caravan and pontoon boats for circulation. Last but not least, the factory also has 2 sets of loading dock for container loading, which will increase a lot of efficiency. There are more than 300 staff working in FOSHAN KINDLE TECHNOLOGY CO., LTD, most of the skillful workers have worked here more than 10 years, and around 20 engineers in R&D and mechanic engineering department. QA department developed an integrated quality controlling system, there are more than 20 QC staff supervise each process.



## TRAY AND CANOPY PACKAGE

- Canopy Dimension: 1800\*1800\*860mm ( other size could be customized )
- Material: 2.5mm Flat Aluminum
- Surface treatment: Powder coat (Any color is available)
- Adjustable lift off jack legs: 304 Stainless steel
- The roof top includes mattress and ladder 3 Door Canopy, with a quarter dog box with a separate door .
- Galvanized Steel Tray Size is 1880x1800mm

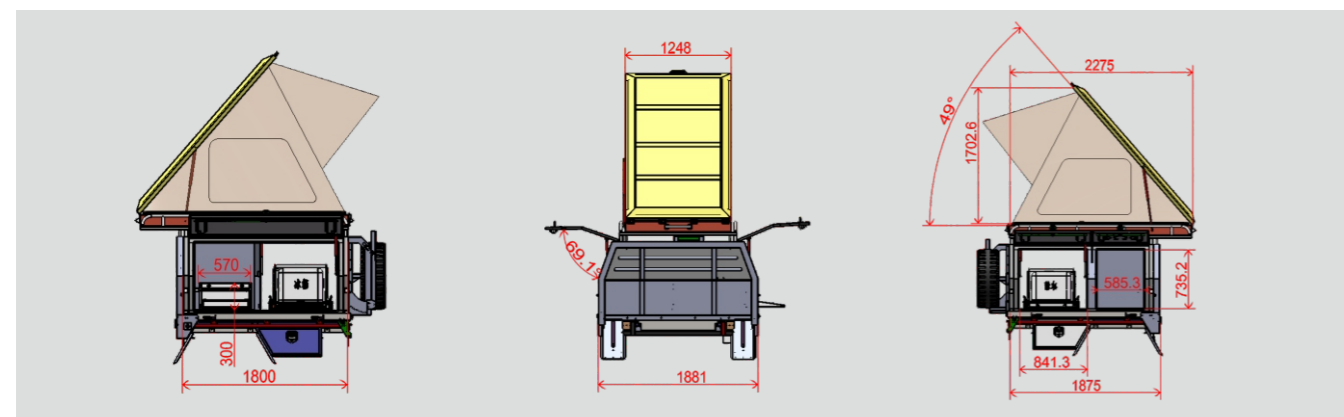
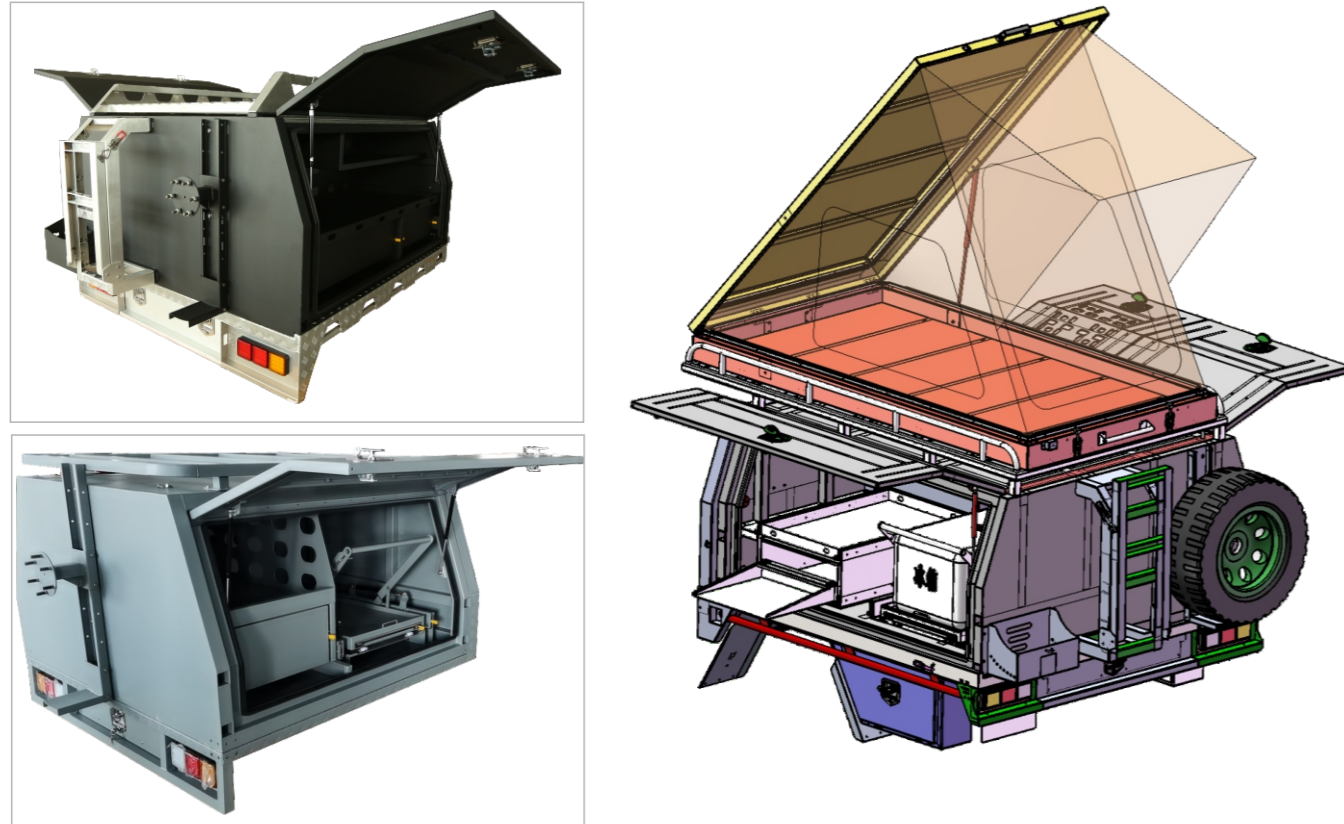

### FEATURES

|                                      |   |
|--------------------------------------|---|
| ▪ 1 x Roof Rack                      | ▪ 1 x Jerry Can Holder                                    |
| ▪ 1 x Fridge Slide                   | ▪ 1 x Aluminium Tent Cover, made by 5052 aluminium 2.5mm. |
| ▪ 1 x Drawer                         | ▪ 1 x tent mattress thickness                             |
| ▪ 1 x Slide out Tray from the drawer | ▪ 1x telescopic ladder                                    |
| ▪ 1 x Rear Spare Tire Holder         | ▪ G.W is 600kg  |
| ▪ 1x Small flip-up tray              |   |

## ADVANCED MODEL ALUMINUM UTE CANOPY WITH ROOF TOP TENT

- Dimension: 1650\*1800\*860mm
- Material: 2.5mm Flat Aluminum
- Surface treatment: Dark Grey Powder coat
- Adjustable lift off jack legs: 304 Stainless steel with brushed surface
- The roof top includes mattress and ladder



### FEATURES

|  |                              |
|--|------------------------------|
| ▪ 3 Door Canopy, with a quarter dog box with a separate door |                              |
| ▪ 1 x Roof Rack  | ▪ 1 x Rear Spare Tire Holder |
| ▪ 1 x Fridge Slide   | ▪ 1 x Jerry Can Holder       |
| ▪ 1 x Drawer   | ▪ 1 x Tent                   |



## FORD RANGER DOUBLE CAB ALUMINIUM CANOPY CAMPER

- Ford Ranger double cab 5 foot
- Material: 3.0mm checker plate
- An easy-access vertical door with heavy-duty hinges, and the ability to mount a 33" spare-wheel
- Tried and tested dual-layer canvas tent for better thermal
- Flip-away bed means ample headroom and standing
- 2 Side-access canopy doors

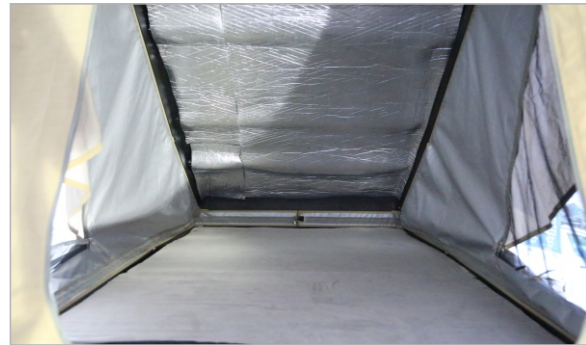

## MULTI-FUNCTIONAL ALUMINIUM DUAL CAB CANOPY

- Size: 1800\*1800\*860mm
- Weight: 87 kg
- Material: 2.5mm flat aluminium plate
- Surface treatment: powder coating with gloss white



### FEATURES

- 2\* doors
- 1\* fridge drop slide & mount (50L fridge)
- 2\* interior partitions around the fridge
- 1\* heavy duty drawer 860\*800\*400mm,
- 4\* jack of legs



## LIGHT WEIGHT MID SIZE SLIDE IN TRUCK CAMPER

- Body Dimensions: 3040 L x 2160 W x 1343.9 mm
- Inside Dimensions: 2910 L x 1934 W x 1254.4 mm
- Base Frame: aluminium plate + aluminium frame + XPS + plywood
- Floor structure : honey comb plate + pvc floor glue
- Manual roof lift : about 800mm height when it opened
- Size of double-bed: 1934 x 1355 mm



## FEATURES

- |   |                                      |
|---|--------------------------------------|
| ▪ Pneumatic lifting table x 1                                     | ▪ Windows 900 x 450 mm x 2           |
| ▪ Black imitation leather sofa x 4                                | ▪ Caravan door 700 x 1000 mm x 1     |
| ▪ Fresh water tank: 85L   | ▪ Pop up tent (with windows)         |
| ▪ Pump: 12V, 11.3 LPM water flow                                  | ▪ Manual awning: 2500 x 2000 mm      |
| ▪ Gravity inlet + pressure reducing water inlet                   | ▪ Locable lock x 4                   |
| ▪ Rear door exterior wall light x 1                               | ▪ Jack off legs x 4                  |
| ▪ Lithium battery 12V 300AH                                       | ▪ 240V outlets x 2                   |
| ▪ Sine wave inverter: 3000 W, with charging function              | ▪ 240V and 12V circuit breaker       |
| ▪ Electricity meter x 1, water level meter x 1                    | ▪ Led lights Dometic portable toilet |
| ▪ 10 external mains socket: 220V-240V, 16A and 10 m charging cord |                                      |
| ▪ Car 12V power socket: USB port x 2 + cigarette lighter x 1      |                                      |

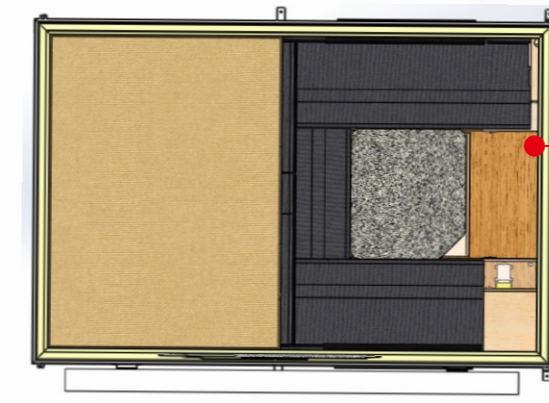

Layout





## FLATBED POP UP TRUCK CAMPER

- Body size: 3838(L)\*1854(W)\*1480(H) / mm (can be raised by 800)
- Interior dimensions: 3768(L)\*1784.5(W)\*1332(H) / mm (can be raised by 800)
- Tare Mass: 510KG
- Body structure: FRP+aluminum frame +XPS+ FRP
- Floor structure: FRP+aluminum frame +XPS+ FRP
- Double bed size: 2000\*1754mm
- Sofa bed Size: 1786\*738mm
- Kitchen space: 1786\*738mm



Layout

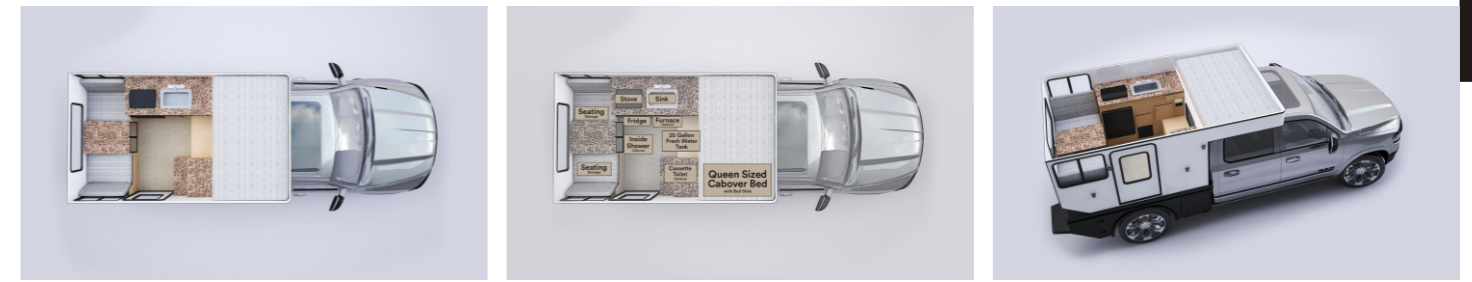

### FEATURES

|  |   |
|--|---|
| ▪ Seats on sofa: 4   | ▪ Solar energy controller: 20A                |
| ▪ Sofa material: grey leather-proof sofa                             | ▪ Solar panels: 12V, 100W*2                   |
| ▪ Fresh water tank: 100L   | ▪ External socket: 220V-240V, 15A             |
| ▪ Gravity water inlet  | ▪ External charging cable: 10m                |
| ▪ Pressure water inlet   | ▪ 240V circuit breaker                        |
| ▪ Sink with cover  | ▪ 12V circuit breaker: special for automobile |
| ▪ 5KG gas bottle rack *2   | ▪ 240V power socket inside: 2 (mirror)        |
| ▪ Front car connector: 7-core flat connector                         | ▪ Water level display: fresh water level      |
| ▪ 50A Anderson plug  | ▪ Lighting: LED light set                     |
| ▪ Side lights: 2 exterior wall lights                                | ▪ Thetford 76L DC 12V refrigerator            |
| ▪ Reflector  | ▪ Thetford three-head stove                   |
| ▪ ble the table  | ▪ Thetford toilet                             |
| ▪ Water heater: Truma 14L electrical integration                     | ▪ CO alarm, Smoke alarm and Gas alarm         |
| ▪ Water pump: 12V water pump with flow rate of 11.3LPM               | ▪ Handle with light                           |
| ▪ Bathroom shower: adjustable height (Water Mark certification)      | ▪ Awning: 2500(L)*2000(W)/ mm, manually       |
| ▪ Wash basin faucet: warm and cold faucet (Water Mark certification) | ▪ 4 * Jack legs                               |
| ▪ Battery: maintenance-free battery, 12V150AH                        | ▪ Fire extinguisher                           |
| ▪ Sine wave inverter, 12V to 240V, 2000W, with charging function     | ▪ RANGER bathroom ventilator                  |
| ▪ Electricity display: electricity meter (digital display)           | ▪ Pop up tent: 3838*1850*800mm                |
| ▪ 12V power socket inside: USB socket*4+ cigarette lighter*2         | ▪ Bathroom curtain: 638*688mm                 |
| ▪ Windows: 1000*400*1, 700*400*2 and 280*457*1                       | ▪ Exterior city plug and USB socket           |
| ▪ Hatches: 350*300*1, 250*300*1, 300*600*1, 400*500*1                | ▪ Table: Manually rotate and disassem         |





## FIBERGLASS MOLDULAR SLIDE ON TRUCK CAMPER

- Body size: 3358(L)\*1755(W)\*1567.5(H) / mm
- Interior dimensions: 3315(L)\*1675(W)\*1436(H) / mm
- Body structure: FRP+flame retardant board
- Floor structure: FRP+flame retardant board +PVC floor glue
- Slide bed size: 2000\*1350 mm
- Sofa bed size: 1600\*965 mm
- Kitchen space: 1600\*965 mm



Layout

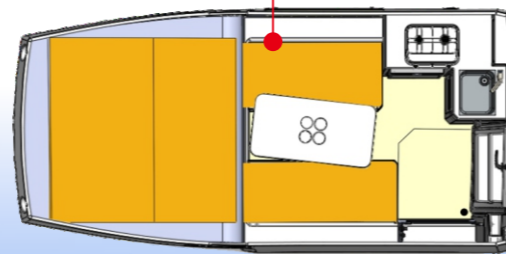

## FEATURES

- |  |                                   |
|--|-----------------------------------|
| ▪ STable: Removable lifting table  | ▪ Battery switch                  |
| ▪ Seats on sofa: 4   | ▪ 12V fuse                        |
| ▪ Sofa: Fabric sofa  | ▪ 220V circuit breaker            |
| ▪ Fresh water tank: 85L  | ▪ Lighting: LED light set         |
| ▪ Grey water tank: 16L   | ▪ Dometic 50L DC 12V refrigerator |
| ▪ Water heater: 12V&220V dual power supply 10L   | ▪ Airtronic air heater            |
| ▪ Water pump: 12V water pump with flow rate of 11.3LPM   | ▪ Two head gas burner with cover  |
| ▪ Gravity water inlet  | ▪ Dometic portable toilet 976     |
| ▪ External quick connector+external shower (hot and cold water)  | ▪ Windows: 2 x 700*300 mm         |
| ▪ Wash basin faucet: hot and cold faucet   | ▪ Handle with light(exterior)     |
| ▪ Sink with cover  | ▪ 2 x Handle with light(interior) |
| ▪ Front car joint: 7-core round joint (European standard)  | ▪ CO alarm and smoke alarm        |
| ▪ 50A Anderson plug  | ▪ Tent: double layer with windows |
| ▪ Battery: lithium battery, 12V120AH   | ▪ Awning: 2m*1.5m, electric       |
| ▪ 2 x 4.81KG gas bottle rack   | ▪ Traction mat                    |
| ▪ Gas pipe system  | ▪ Fire extinguisher               |
| ▪ Soft solar panels: 12V, 100W*2   | ▪ 4 x Jack legs                   |
| ▪ Coulometer: capacity, voltage, current, power and temperature  | ▪ Battery isolator                |
| ▪ Water level display: fresh water tank and grey water tank  | ▪ MPPT solar controller: 20A      |
| ▪ 12V power socket inside: USB socket *2+ cigarette lighter *1   |                                   |
| ▪ Two position light(Front head) , two reversing light and two lights with brake position and cornering function(Tail light) |                                   |





## EXPEDITION TRUCK CAMPER

The 11 foot unit Lifting Top has an aluminium frame and weighs less than 1,600kg. With such a low dry weight rating, this model is particularly suitable for vehicles with limited load carrying capacity like the Iveco Daily.



### Interior:

- Main bed configuration (L x W) : High Bed (2000 x 1400 mm)
- Couch configuration: U-shape couch
- Couch bed (L x W) :2000 x 1450 mm
- Kitchen countertop (L x W x H) : Corian worktop with 2 induction hobs (1120 x 622 mm)
- Stove: 2 induction hobs 2 induction hobs
- Fridge: 85 Liter
- Extractor hood: with carbon filter with carbon filter
- Shower and toilet configuration (L x W x H):combined shower and toilet (650 x 615 x 1900 mm)
- Toilet: Cassette Toilet- Thetford



Layout

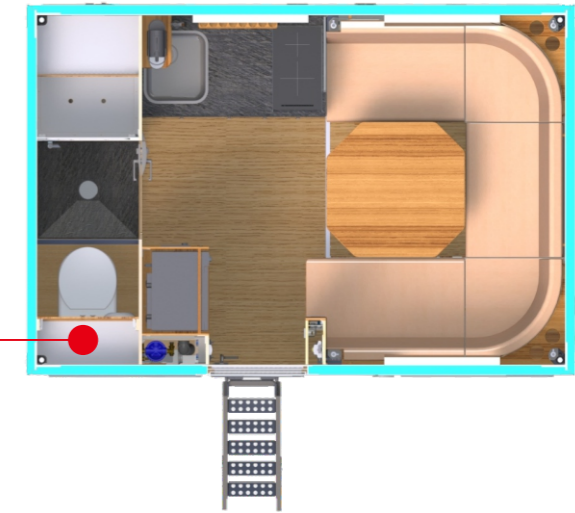

### Exterior::

- Outside dimensions (L x W x H): 3358 x 2270 x 2236 mm
- Total dry weight: 1600 kg
- Inside garage dimensions (L x W x H): 280 x 610 x 700 mm
- Garage hatch (L x W): 1x hatch small (500 x 600 mm)
- Fresh water tank capacity: 410 Liter
- Grey water tank capacity: 120 Liter
- Black water tank capacity: 105 Liter

### Energy:

- Maximal solar power: 2 pcs 100W solar panel
- Batteries: Free-maintenance batteries 120amp
- Inside power connections: 4x 220-240V Volt, 6x USB

